

PROPER USE GUIDELINES

Cumulative Trauma Disorders can result from the prolonged use of manually powered hand tools. Hand tools are intended for occasional use and low volume applications. A wide selection of powered application equipment for extended-use, production operations is available.

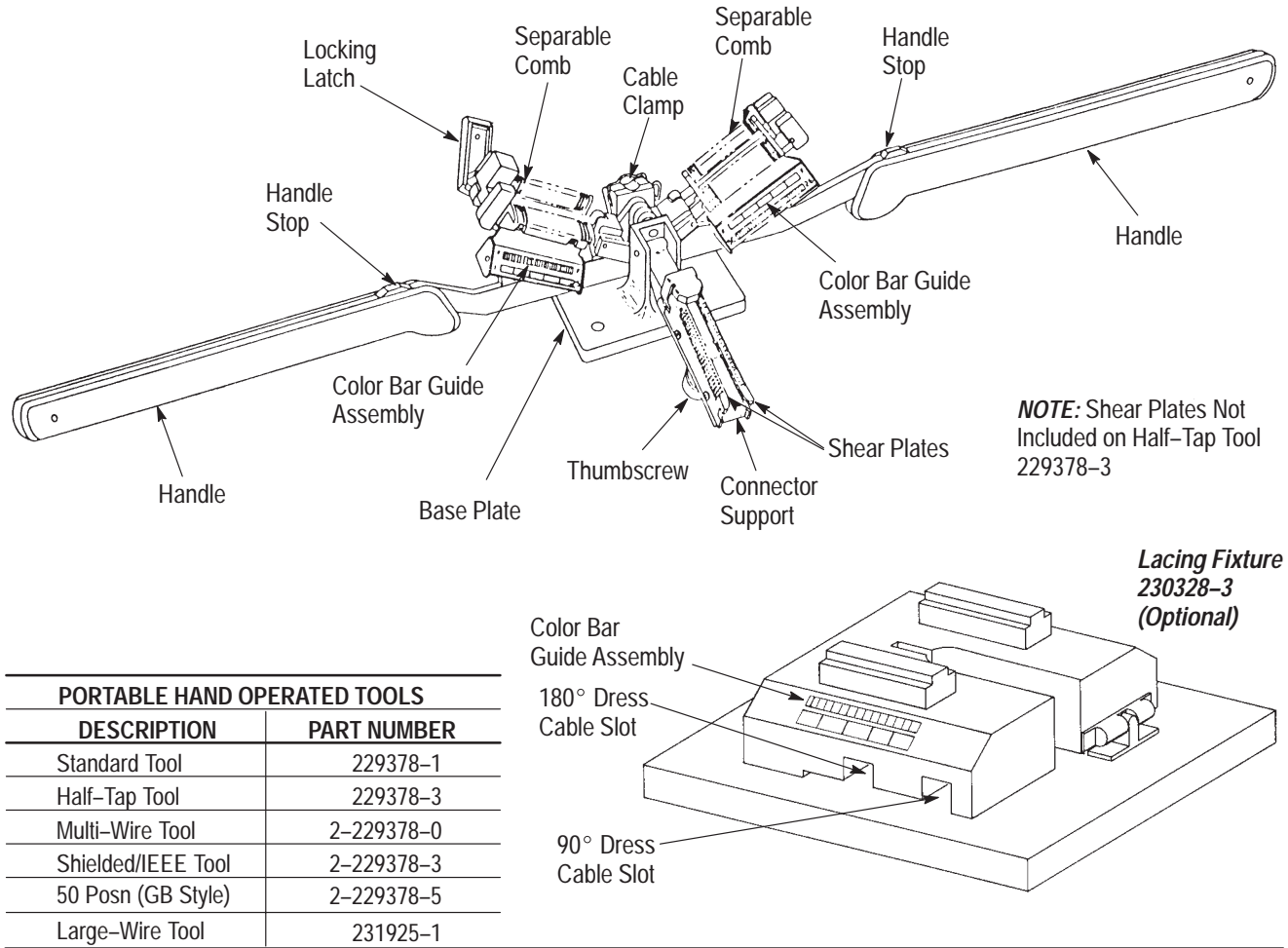

PORTABLE HAND OPERATED TOOLS	
DESCRIPTION	PART NUMBER
Standard Tool	229378-1
Half-Tap Tool	229378-3
Multi-Wire Tool	2-229378-0
Shielded/IEEE Tool	2-229378-3
50 Posn (GB Style)	2-229378-5
Large-Wire Tool	231925-1

Figure 1

1. INTRODUCTION

AMP* CHAMP Portable Hand Operated Tools 229378-[] and 231925-1 (see Figure 1) are designed to terminate 14-, 24-, 36-, and 50-position CHAMP connectors using the Insulation Displacement Crimp technique without any modification or conversion. The tools may be converted to perform various functions; see Section 12.

Refer to Catalog 82008 for CHAMP connector part numbers.

NOTE Dimensions on this sheet are in metric units [with U.S. customary units in brackets]. Figures and illustrations are for identification only and are not drawn to scale.

Reasons for reissue are provided in Section 13, REVISION SUMMARY.

2. DESCRIPTION

The MI-1 tools listed in Figure 1 may be used with the combs in place on the tool or with the combs removed from the tool and positioned on the optional lacing fixture. If lacing on the tool, wires may be laced into the combs to produce a 90° cable dress connection. If lacing remotely using the optional lacing fixture, wires may be laced into the combs to produce either a 90° or a 180° cable dress connection.

NOTE Tool 2-229378-3, for the shielded connectors, must be set up with the combs in place on the tool.

The remote lacing feature enables the user to lace wires on one set of combs while another operator terminates a connector using another set of combs in the MI-1 tool. In addition to the standard tool which is designed for conventional applications, four other versions of the MI-1 tool are available for special applications. They are:

Tool 229378-3—provides a half-tap (“daisy chain”) application when more than one connector is to be attached to the same group of wires (conductors are not cut during termination).

Tool 2-229378-0—provides a two-wire insertion application when more than one wire is inserted into one contact slot (terminates 26 AWG solid conductors only).

Tool 2-229378-3—provides termination of the following 24-position CHAMP shielded connectors: IEEE-488 Connector Kit 553576; Low-Cost Back-to-Back Connector 555182; and Low-Cost 90° Connector 555183.

Tool 2-229378-5—provides termination for 50 position Great Britain CHAMP Connectors. P/N 341467-7 and Viking CS00070-1, Red Dot.

Tool 231925-1—provides termination of large diameter insulation (1.42 [.056] maximum), 22 AWG wires, in F-slot CHAMP connectors up to 50 positions.

The features of the tool are as follows:

Base Plate—Supports functional components of the tool, and can be secured to the work bench.

Handles—Retain wire stuffers/inserters and provide insertion force. Stops on handles prevent overinsertion of wires during terminating process.

Color Bar Guide Assembly—Ensures correct orientation of wires in slots of connectors.

Shear Plates—Aligns wire with cable slots and enables wires to be sheared.

Connector Support—Holds connector in proper position and provides surface (shear plates) for cutting off excess wire.

Spring Lock—Affords positive lock when connector support is in “UP” position.

Thumbscrew—Retains connector securely in connector support.

Wire Combs (Separable)—Separate and hold wires that are laced into tool or predressed in lacing fixture.

Wire Comb Supports—Support wire combs and locking latch.

Cable Clamp—Holds wire in position on the tool during lacing procedure.

Locking Latch—Holds wire comb supports together during termination of wires.

Inserters and Wire Stuffers—Cut and simultaneously insert wires between contact slots.

Lacing Fixture—Holds the combs, supports the wire during lacing procedure, and allows the wire to be predressed at 90° or 180°. Color-coded decals are included for wire lacing visual identification.

With the exception of connectors with F-slot contacts, CHAMP connectors are available in various styles and will accommodate a wire size range of 26-22 AWG solid conductors or 28-22 AWG stranded (7-strand only) conductors and a maximum insulation diameter of 1.14 [.045]. These connectors can accept wires having soft insulation, such as pvc or polyethylene. Connectors with F-slot contacts will accommodate only 22 AWG wires with either solid or stranded (7-strand only) conductors and a maximum insulation diameter of 1.42 [.056].

3. POSITIONING TOOL FOR USE

Select a sturdy work bench that is a convenient height for the operator. Position the tool on the work bench: make sure there is sufficient space at the back of the tool to permit handling of the wire bundle, and *make sure tool handles can open fully*. Secure the base plate to the work bench. Make certain the work area is well lighted, and that the area around the tool is kept clear for operation of the handles.

4. WIRE PREPARATION (Figure 2)

The procedure which follows has been prepared for standard color-coded wires. The same method of operation will apply for nonstandard color-coded wires; however, the wire groups MUST be defined in some other way.

Proceed as follows:

1. Remove approximately 203 [8.000] length of sheathing from end of wire. Do NOT cut or nick insulation of individual wires.

NOTE

If using connector with short tapered cover, slit wire sheathing back 25.4 [1.00]—then fold sheathing back over itself before placing wire in tool.

2. Separate wires into color groups (predominantly white in one group, predominantly red in one group, etc.).
3. Wrap a piece of wire around each group to keep the groups separated.

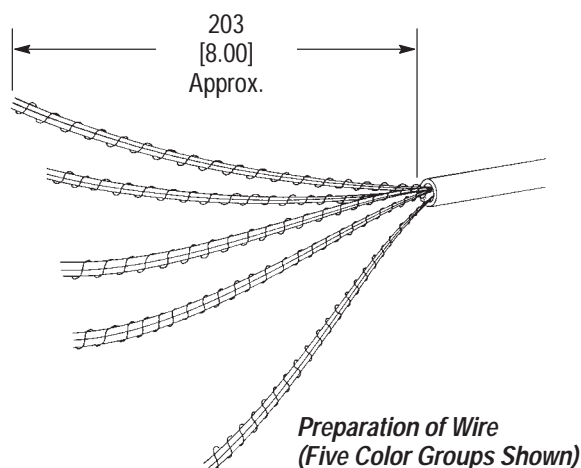

WIRE		
WIRE SIZE RANGE, AWG	CONDUCTOR TYPE	INSULATION DIAMETER
26-22	Solid	1.14 [.045] Max
28-22	Stranded (7 Strands)	
22■	Solid and Stranded (7 Strands)	1.42 [.056] Max

■Used only with tool 231925-1.

Figure 2

5. TERMINATING PROCEDURE

5.1. Tools 229378-1, 2-229378-0, 2-229378-5, and 231925-1

A. Placing Wires and Connector in Tool

1. Open tool handles fully. Push on left side of locking latch until it snaps open; then push on right side to open latch completely. Refer to Figure 1.
2. Rotate both wire comb supports outward and move connector support down. The tool is now ready to receive the connector and wires.
3. Loosen thumbscrew by rotating it COUNTERCLOCKWISE several turns.
4. Select the appropriate plug or receptacle connector size for the application. Align connector with FRONT of connector support—make sure arrow on connector faces toward tool operator and LOW number positions are to the LEFT, as shown in Figure 3. Insert connector into connector support (between shear plates) until it bottoms.

NOTE

Figure 3A refers to standard applications for CHAMP connectors and Figure 3B refers to the Modified Wiring Pattern for CHAMP SYSTEM 5 Connectors.

5. Turn thumbscrew CLOCKWISE until connector is securely held.

6. Verify whether a plug or receptacle connector is to be terminated. Then proceed as follows:

a. *If Lacing on Tool*—Check lettering on ends of color bar for compatibility. “M” is for male (plug) connectors and “F” is for female (receptacle) connectors. If necessary, rotate color bar 180° to obtain the applicable lettering.

b. *If Lacing Remotely*—Remove separable combs from tool and place them on lacing fixture.

7. Insert wire as follows:

a. *If Lacing on Tool*—Open cable clamp and insert wire until sheathing extends approximately 12.7 [.500] above the base plate. Hold wire in position and close the wire clamp. See Figure 4.

b. *If Lacing Remotely*—Pivot lacing fixture upward and insert wire into either 90° or 180° cable slot until sheathing is on the same plane as the comb shoulders (see Figure 5).

8. Pull first group of wires forward and remove piece of wire installed in preparing the wire (Section 4, Step 3). Separate wires by tracer and body color (ring and tip). Place ring wires to the LEFT and tip wires to the RIGHT.

9. Lace wires into combs. When lacing on tool, start toward the center; when lacing on fixture, start toward the end nearest detent lock on lacing fixture. Take wire from one side (LEFT or RIGHT) and lace wire through rear comb teeth and into corresponding position in front comb teeth. While keeping wire taut, bend wire under front comb and, when lacing on tool, around inside of guide supports. See Figures 4 and 5.

10. Take mating wire from opposite side of tool (lacing fixture) and lace it through the combs—wire color code must correspond with color bar (see Figure 3).

11. Repeat Steps 8, 9, and 10 until half of the wire bundle is laced into the combs.

a. *If Lacing on Tool*—After bending first half of wire bundle around inside of guide supports (toward center of tool), change direction and bend second half of wire bundle around outside of guide supports (toward tool handles).

b. *If Lacing Remotely*—Continue lacing second half of wire bundle and bending wire under front comb.

**Standard Application
for CHAMP Connectors**

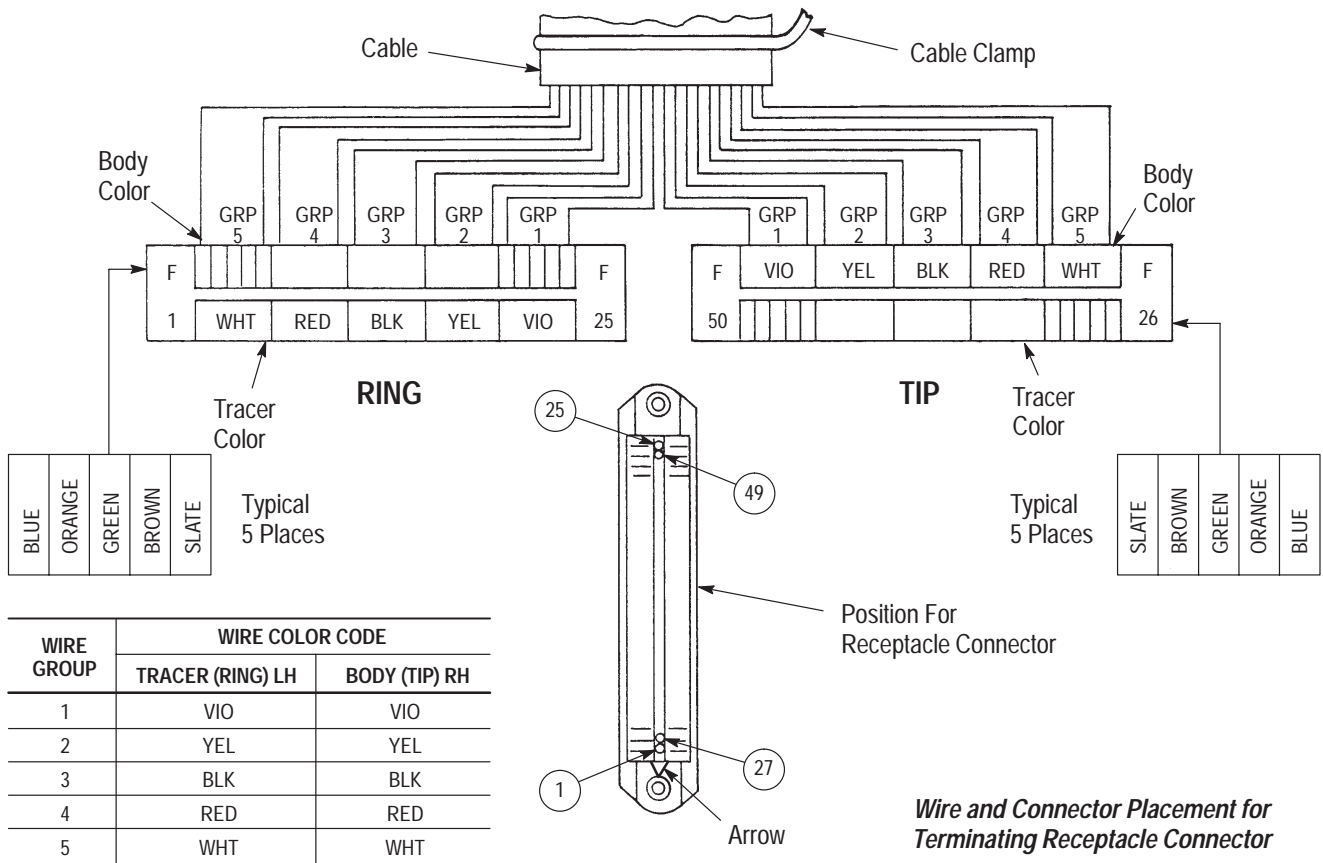
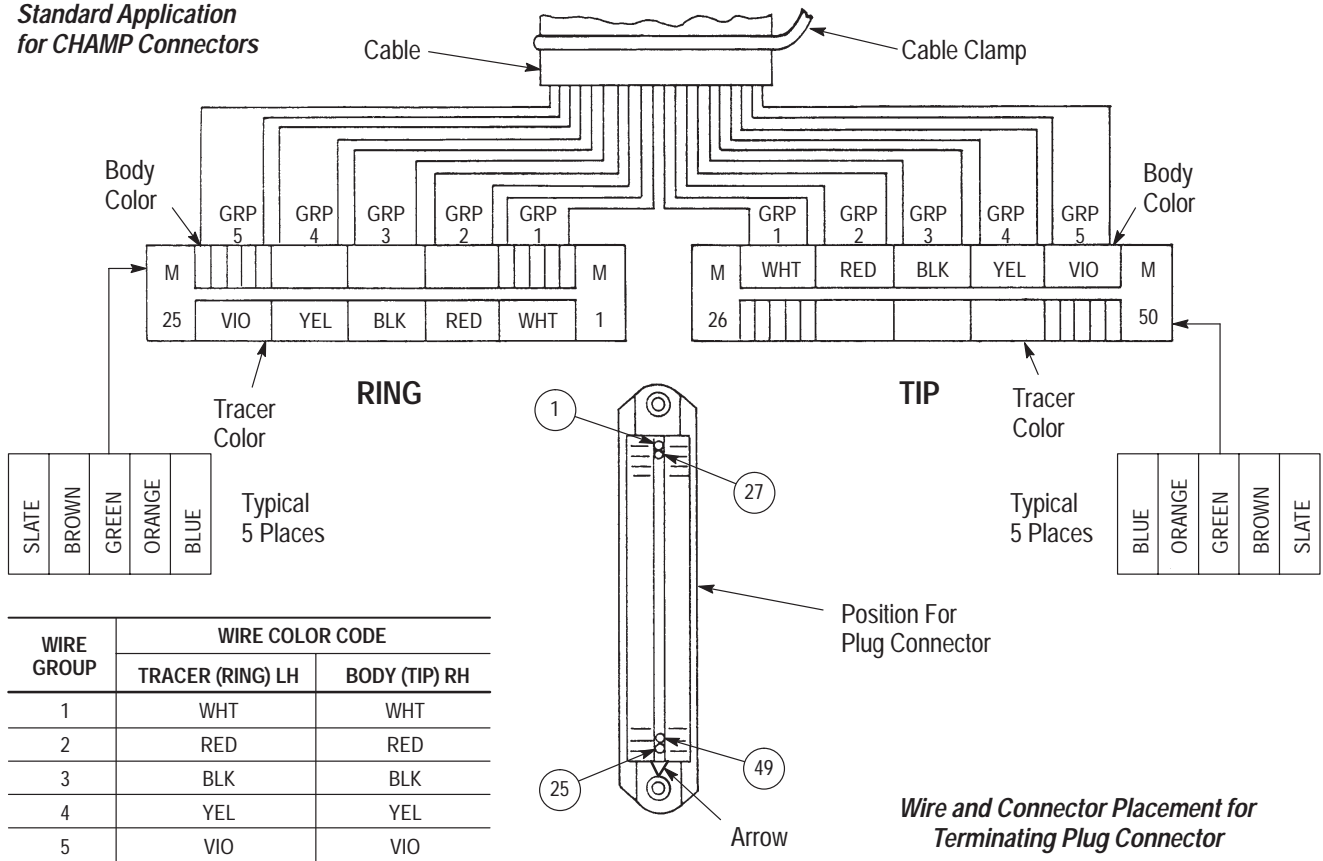
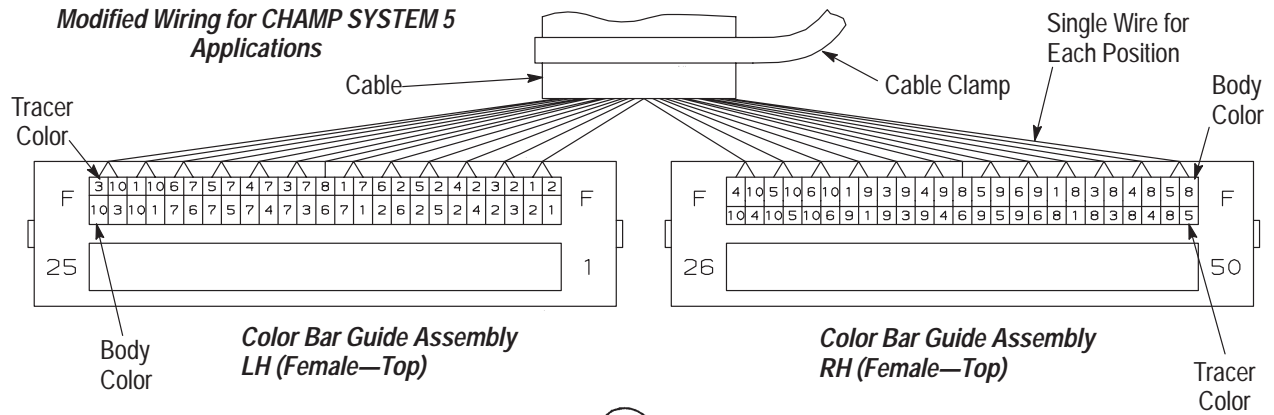
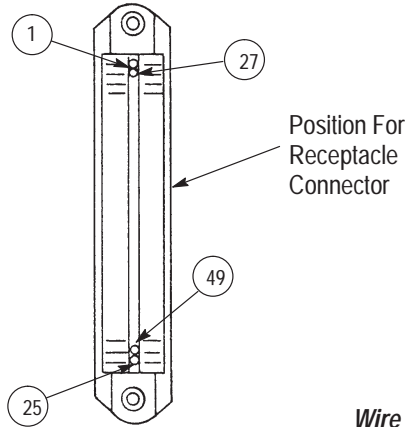

Figure 3A



NOTE: A Maximum of 12.7 [.50] Untwist is Allowed in Each Pair to Termination Point for CATEGORY 5 Performance.

COLOR CODE	COLOR	COLOR CODE	COLOR
1	BLUE	6	GRAY
2	WHITE	7	RED
3	ORANGE	8	VIOLET
4	GREEN	9	YELLOW
5	BROWN	10	BLACK



Wire and Connector Placement for Terminating Receptacle Connector

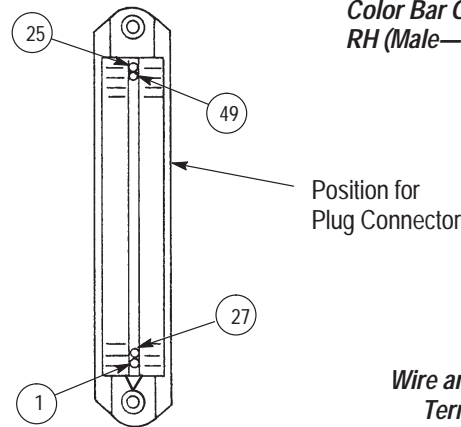
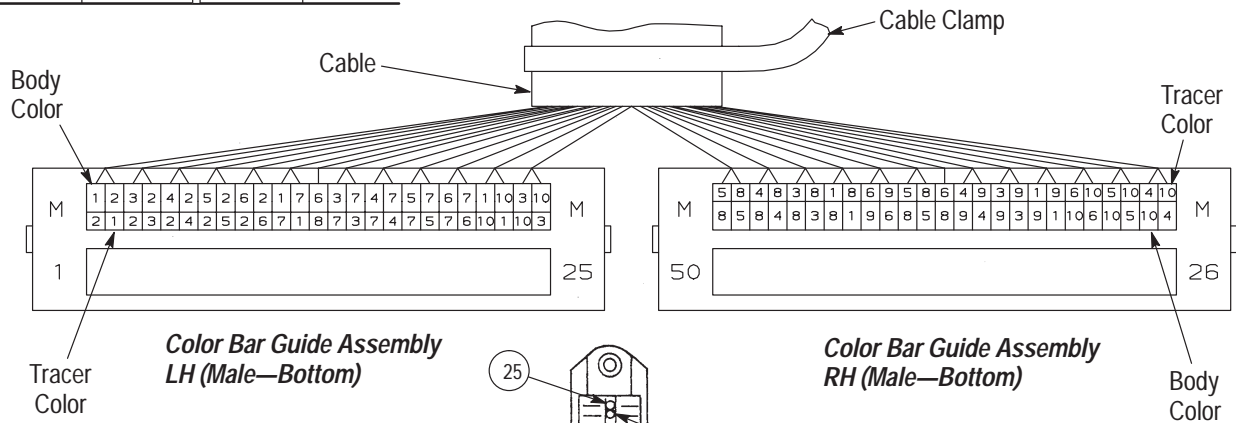

Wire and Connector Placement for Terminating Plug Connector

Figure 3B

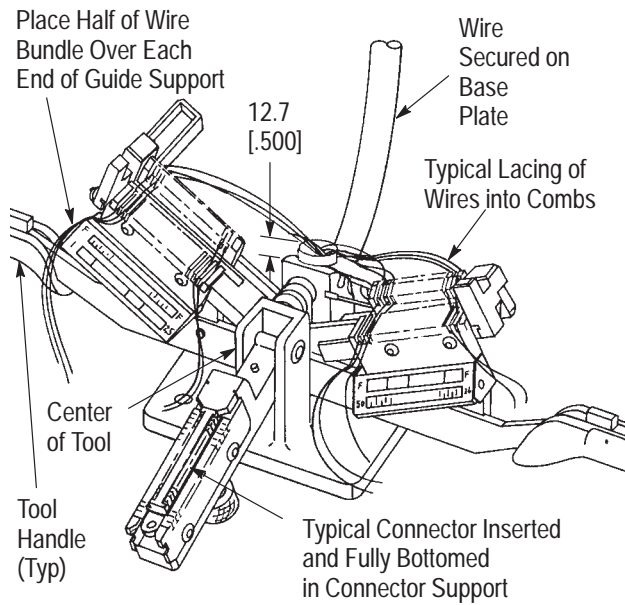

Figure 4

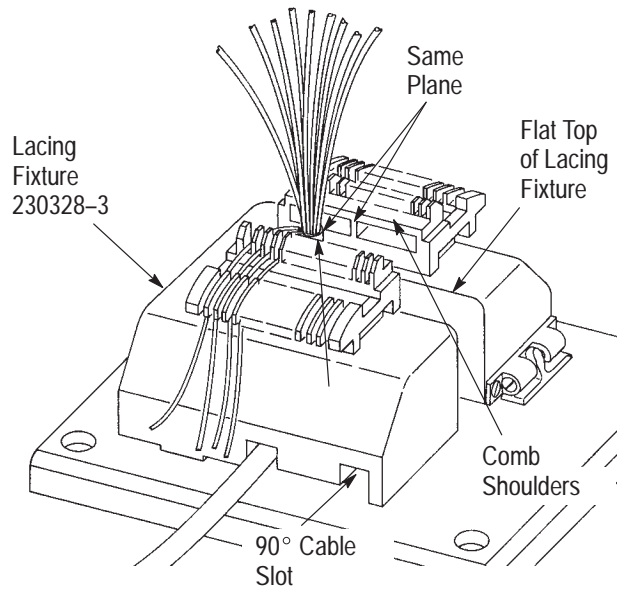

Figure 5

B. Tool Operation (Figure 6)

1. Check to be sure all wires are parallel in the combs. Make sure connector is bottomed in connector support.
2. Raise connector support to vertical position.
3. Be careful that the wires remain in the combs. Proceed as follows:
 - a. *If Lacing on Tool*—Raise one wire comb support to a vertical position and, while holding it in place, raise other wire comb support to a vertical position.

b. *If Lacing Remotely*—Carefully remove combs from lacing fixture. Position one comb on wire comb support and snap comb into place. Raise this wire comb support to a vertical position and, while holding it in place, snap second comb onto other wire comb support and raise it to a vertical position.

4. Hook locking latch onto RIGHT wire comb support. Press on LEFT side of locking latch until it is secure.
5. Look into sides of both wire comb supports to check alignment of wires. Each conductor must be aligned with a single contact.
6. Raise tool handles until the stops on the handles butt against each other (these are two-handed tools, and the handle stops must bottom). This shears all wire ends and fully inserts all wires.
7. Remove sheared wire ends from combs. Lower the tool handles.
8. Loosen thumbscrew by turning it COUNTERCLOCKWISE.
9. Open locking latch and rotate wire comb supports downward.
10. Open cable clamp (if applicable). Slide terminated connector straight out of connector support.
11. Inspect all terminations as described in Section 6.

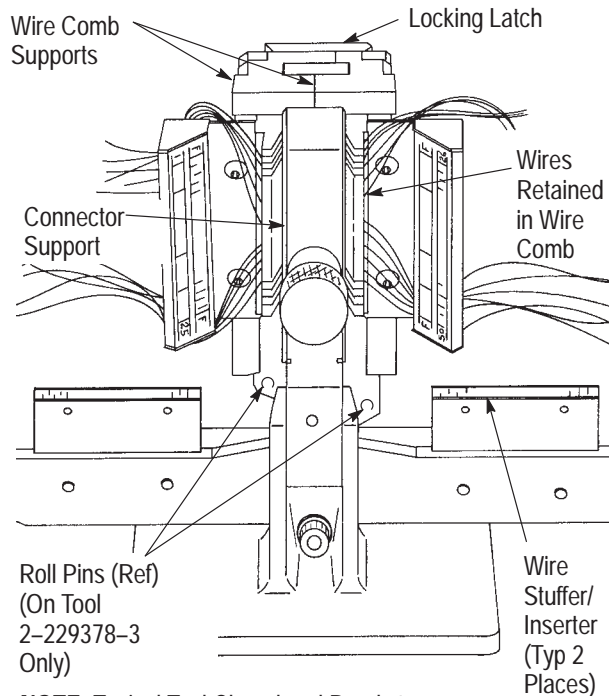

NOTE: Typical Tool Closed and Ready to Terminate Wire in Connector.

Figure 6

5.2. Tool 229378-3

A. Placing Wires and Connector in Tool

Follow the steps listed in Paragraph 5.1,A.

B. Tool Operation (Figure 6)

Follow Steps 1 through 5 listed in Paragraph 5.1,B. Then proceed as follows:

1. Raise tool handles until the stops on the handles butt against each other (these are two-handed tools, and the handle stops must bottom). This fully inserts all wires.
2. Lower the tool handles.
3. Continue with Steps 8 through 11 in Paragraph 5.1,B.

5.3. Tool 2-229378-3

A. Placing Wires and Connector in Tool

This application involves termination of the 24-position shielded connector (IEEE-488, Low-Cost, Back-to-Back, and Low-Cost 90° Connectors) in Tool 2-229378-3. Proceed as follows:

1. For instructions on wire preparation, connector shield assembly, and dressing order of the conductors in the connectors, refer to the instruction sheet packaged with the connector.
2. Follow Paragraph 5.1,A for placing wires and connector in tool, except as follows:
 - a. Load connector into connector support with receptacle (female) down and with Position 13 to the right (except 90° connector (male), Position 13 will be to the left).
 - b. Open cable clamp and insert wire until sheathing extends approximately 12.7 [.500] above the base plate. Hand wire in position and close cable clamp. See Figure 4.

B. Tool Operation (Figure 6)

Follow the steps listed in Paragraph 5.2,B.

6. INSPECTION OF TERMINATIONS

Visually inspect the wire terminations in the connector for the following:

1. Make certain wire is inserted evenly so that the insulation is below the V-shaped lead-in on both the contact slot and the strain relief slot. See Figure 7.
2. Check that all wires have been sheared (if applicable) to the proper length (extends at least

50% of the distance between the contact slot and the housing), and does not have more than 0.38 [.015] maximum conductor exposure.

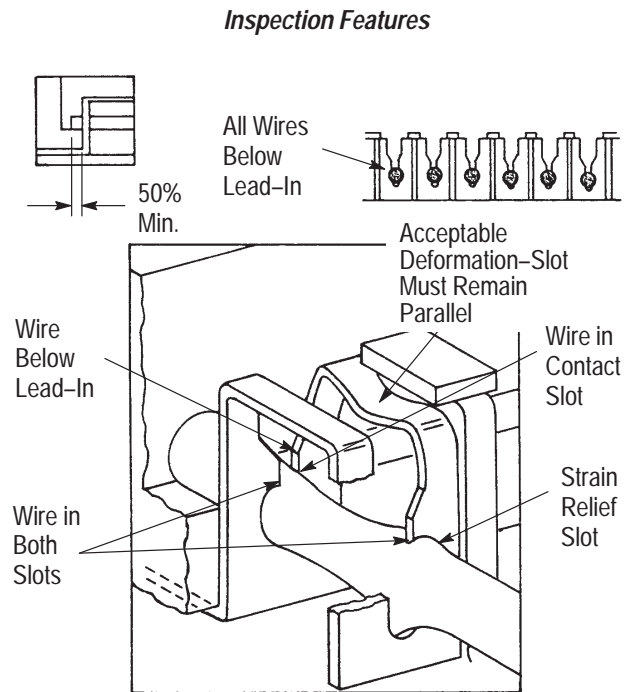

Figure 7

3. Check that the insulation is NOT cut in any area other than the slot insertion area.
4. Check to be sure the contacts are NOT deformed or crushed.
5. Make certain the conductors have NOT been cut above strain relief slot in the contacts.

NOTE

If any of the wires are NOT properly terminated, re-insert them using T-Handle Insertion Tool 229384-1. Refer to Instruction Sheet 408-7558, packaged with this tool, for operating instructions.

7. TOOL INSPECTION

CHAMP Portable Hand Operated Tools should be inspected with the information provided in Figure 8. Tyco recommends that the tool be inspected immediately upon arrival at your facility, and at regularly scheduled intervals, to ensure that the tool has not been damaged during handling.

The parts listed in Figure 8 are customer-replaceable parts. The Item Number column has been included to provide a reference throughout the text; it is not to be used when ordering parts. To order parts, use the Tyco Part Number and Description.

The Quantity Per Tool column indicates the number of each item required for each tool. The Recommended Spares column indicates the quantity of each item required to maintain up to 10 tools for a period of one year under normal circumstances. A complete inventory should be stocked and controlled to prevent lost time when replacement of parts is necessary. Order replacement parts through your Tyco representative, or call 1-800-526-5142, or send a facsimile of your purchase order to 1-717-986-7605, or write to:

CUSTOMER SERVICE (38-35)
TYCO ELECTRONICS CORPORATION
P.O. BOX 3608
HARRISBURG, PA 17105-3608

Tools may also be returned to Tyco for evaluation and repair. For tool repair service, contact a Tyco representative at 1-800-526-5136.

8. DAILY MAINTENANCE

Each operator of the tool should be made aware of—and responsible for—the following steps of daily maintenance.

1. Clean the tool with a soft-bristle brush and/or soft, clean cloth. Do NOT use any type of solvent to clean the tool.
2. Lubricate pivot points in center of tool with a few drops of light machine oil. Apply a thin coat of LUBRIPLATE‡, or equivalent, to sides of the insert. Do NOT lubricate excessively.
3. Frequently inspect tool for wear or other damage. If required, replace parts in accordance with the information provided in Section 9, REPLACING WORN OR DAMAGED PARTS.
4. When NOT in use, store the tool in a clean, dry area with a connector in the connector support and the tool handles in the closed position.

9. REPLACING WORN OR DAMAGED PARTS

This section covers parts replacement of those recommended spares listed in the parts lists which require detailed procedures for removal, installation, and alignment. Refer to Figure 8 and other figures referenced throughout this instruction sheet for assistance.

NOTE

During replacement of parts, use SCREWLOCK† Sealant 23419-4, or equivalent, on all screw threads to insure retention.

9.1. Color Bar Guide Assembly (Figure 8)

1. Note orientation of existing color bar guide assemblies.

2. Spread guide support and remove old color bar guide assembly.
3. From the parts list in Figure 8, select the correct color bar guide assembly.
4. Spread the guide support, then orient and install new color bar guide assembly as noted in Step 1.

9.2. Cable Clamp (Figure 8)

1. Fully open the tool as indicated in Figure 8.
2. Drive slotted spring pin back far enough to remove the old cable clamp.
3. Position new cable clamp and drive slotted spring pin back into place.

9.3. Locking Latch (Figure 8)

1. Using a hex socket wrench key, remove the four screws securing locking latch (Figure 8, Item 12) to BACK of wire comb supports.
2. Position the new locking latch and secure it with four screws.

9.4. Wire Combs (Figure 8)

1. While depressing the rear clip, lift the comb from the tool. Position new comb and snap into place using the rear clip.
2. If misalignment of the wires dictates comb adjustment, proceed as follows: loosen the screws securing the rear clip (see Figure 9) and raise the wire comb support to the vertical position. While looking into the side of the tool, align the comb with the shear plate and tighten the rear clip screws.

9.5. Shear Plates (Figure 8)

CAUTION

NEVER attempt to reface the shear plates. This will destroy the flatness required for shearing all the wires.

1. With tool handles and wire comb supports fully opened, remove the two screws attaching the shear plate to the connector support.
2. Position new shear plate on connector support against the stop and tighten the two screws.
3. With connector support open, push down and back on shear plate to seat it on shoulder of connector support. Hold shear plate in position and tighten the two screws.
4. If opposite shear plate is to be replaced, repeat this procedure. Refer to Section 10 for tool adjustment.

‡ Product of Fiske Brothers Refining Company † Product of Loctite Corporation

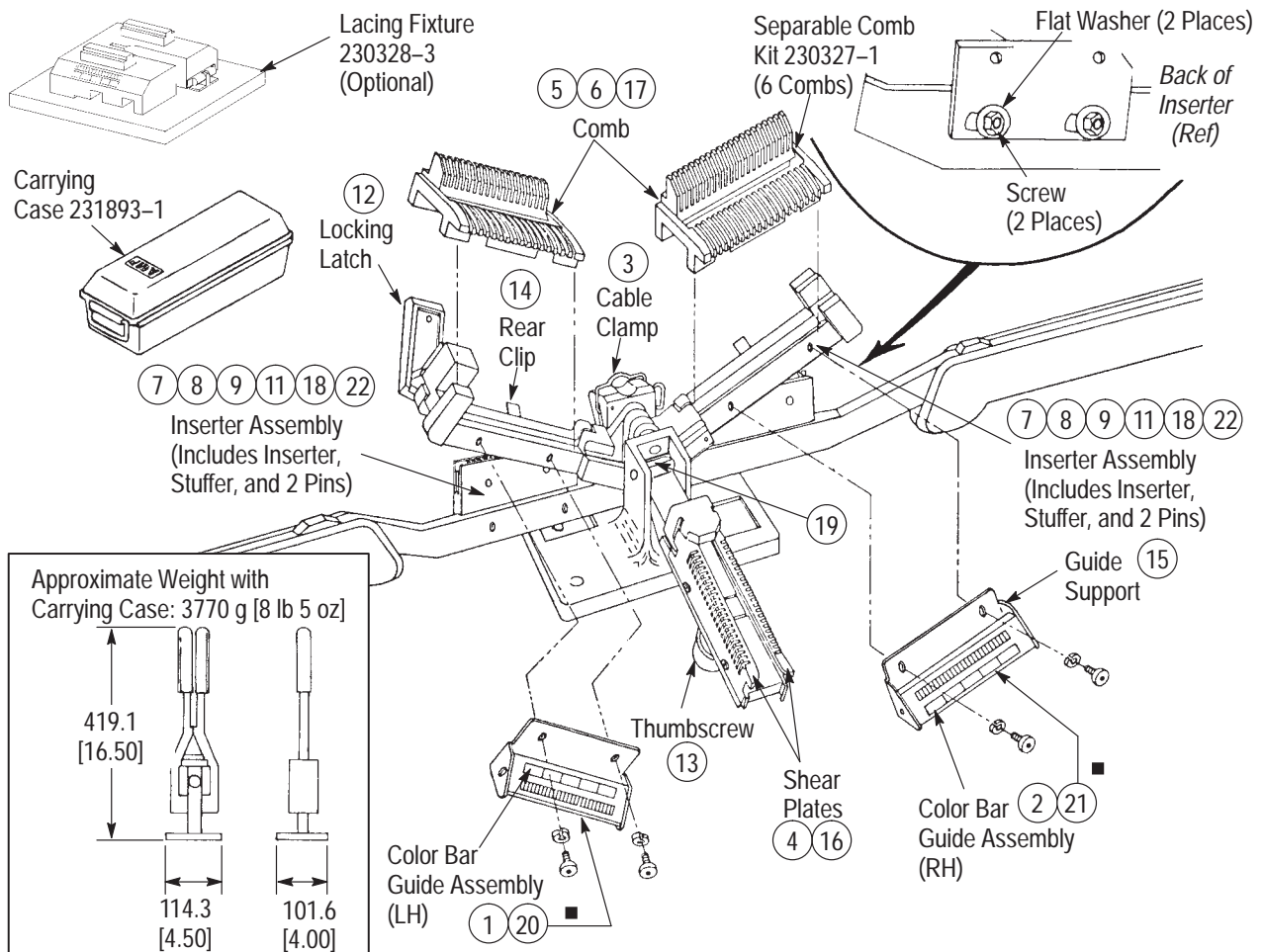

MI-1 TOOLS

Tool 229378-1—Standard
Tool 229378-3—Half-Tap

Tool 2-229378-0—Multi-Wire
Tool 2-229378-3—Shielded/IEEE

Tool 2-229378-5 50 Posn (GB Style)
Tool 231925-1—Large-Wire

REPLACEMENT PARTS

ITEM	PART NO.	DESCRIPTION	QTY PER TOOL	RECM SPARES	ITEM	PART NO.	DESCRIPTION	QTY PER TOOL	RECM SPARES
1	229459-1	GUIDE ASSEMBLY, Color Bar (LH)	1	1	••	231596-2	INSERTER (Shielded/IEEE Tool-RH)	1	1
2	229460-1	GUIDE ASSEMBLY, Color Bar (RH)	1	1	••	231597-2	INSERTER (Shielded/IEEE Tool-LH)	1	1
3•	229622-1	CLAMP, Cable	1	2	••	229474-1	STUFFER (Std and Half-Tap Tools)	2	2
4	231304-1	PLATE, Shear (Except Half-Tap Tool)	2	2	••	231686-1	STUFFER (Shielded/IEEE Tool)	2	2
5	230068-1	COMB, Separable (Except Shielded/IEEE and Large-Wire Tools)	2	4	••	230461-1	STUFFER (Multi-Wire Tool)	2	2
					••	231929-1	STUFFER (Large-Wire Tool)	2	2
6	231387-1	COMB, Separable (Shielded/IEEE Tool)	2	4	••	229405-1	PIN, Inserter	4	4
7	229694-7	INSERTER ASSY (Std Tool)	2	2	12	27314-1	LATCH, Locking	1	2
8	229694-8	INSERTER ASSY (Multi-Wire Tool)	2	2	13	19599-1	SCREW, Thumb	1	2
9	229694-9	INSERTER ASSY (Half-Tap Tools)	2	2	14	230125-1	CLIP, Rear	2	4
10	1-229694-2	INSERTER ASSY (Shielded/IEEE Tool-RH)	1	1	15	229410-1	SUPPORT, Color Guide	2	2
					16	231926-1	PLATE, Shear (Large-Wire Tool)	2	2
11	1-229694-3	INSERTER ASSY (Shielded/IEEE Tool-LH)	1	1	17	231927-1	COMB, Separable (Large-Wire Tool)	2	4
••	229475-1	INSERTER (Std, Multi-Wire and Large-Wire Tools)	2	2	18	231930-1	INSERTER ASSY (Large-Wire Tool)	1	1
••	231023-1	INSERTER (Half-Tap Tool)	2	2	19	229403-1	LOCK SPRING	1	1
					20■	217538-1	GUIDE BAR, Color (LH), SYSTEM 5	1	—
					21■	217539-1	GUIDE BAR, Color (RH), SYSTEM 5	1	—
					22	525129-1	INSERTER ASSY (GB Style)	2	2

• An older style Cable Clamp (229408-1) is also available.
•• Part of Inserter Assembly but can be ordered separately.

■ SYSTEM 5: Item numbers 20 and 21 are also available together in kit form, No. 224105-1.

Figure 8

9.6. Wire Stuffers

The wire stuffers are part of the Inserter Assembly and can be ordered separately. See Figure 8, Replacement Parts. The procedure herein applies to both sides of the tool. It is NOT necessary to remove inserters from the tool. Proceed as follows:

1. With tool handles opened and wire comb supports latched in vertical position, support inserter on a flat surface and, using a drift punch, remove the two inserter pins securing the wire stuffer.
2. Remove wire stuffer from inserter.
3. Position new wire stuffer into inserter and align the holes.
4. Again, support inserter on solid, flat surface. Then, insert two new inserter pins (Figure 8, Replacement Parts).
5. Unlatch wire comb supports, lower connector support and insert connector into connector support until it bottoms. Tighten thumbscrew. Raise connector support and wire combs support to the vertical position. Secure with locking latch.
6. Operate the respective tool handle several times to ensure proper alignment of wire stuffer with contacts. If alignment is incorrect, adjust the inserter as described in Paragraph 9.7.

9.7. Inserters (Figure 8)

The wire inserters are part of the Inserter Assembly and can be ordered separately. See Figure 8, Replacement Parts. The procedure herein applies to both sides of the tool. Note that it may NOT be necessary to replace both inserters. If the replacement of both is required on a single tool, do NOT remove both at the same time.

A. Inserter Replacement

1. With tool fully opened, remove the two screws and two flat washers used to secure the inserter assembly to handle. Remove the inserter assembly.
2. If inserter is being replaced with a new one, check wire stuffer for damage. If wire stuffers are not damaged, remove them and place them in the new inserters, as described in Paragraph 9.6. The same procedure applies if a new wire stuffer must be installed. ALWAYS use new inserter pins.
3. Position inserter on handle. Thread—but do not tighten—the two screws.

B. Inserter Alignment

1. Insert connector into connector support until it bottoms. Tighten thumbscrew. Raise connector

support and wire comb supports to the vertical position. Secure with locking latch.

2. Loosen (approximately one turn) the screws that secure the backup plates (see Figure 9).

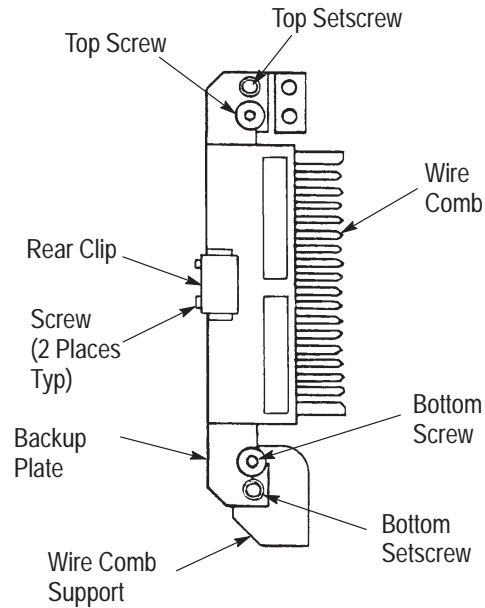

*Rear View—Backup Plate,
Wire Comb Support*

Figure 9

3. Using caution, raise tool handle until new inserter begins to enter the connector. Then, move inserter up or down to align wire stuffer with contacts. When certain that the wire stuffers have aligned with the contacts, close tool handles fully and tighten screws just enough to hold alignment.
4. If opposite wire inserter is to be replaced, repeat replacement and alignment procedures.
5. Before tightening inserter screws and backup plate screws, see Section 10 for tool adjustment.

10. TOOL ADJUSTMENT FOR PROPER WIRE CUTTING

1. Raise the connector support and then the wire comb supports to the vertical position. Secure with locking latch.
2. Slowly raise handles—if inserter binds or has excessive drag—STOP. Re-open handles and adjust backup plate as stated in Step 3. Do NOT force handles closed.
3. Lower handles. Grip connector support and wire comb support with one hand and release locking latch. Now, loosen TOP screw and setscrew, and BOTTOM screw and setscrew securing backup plate to wire comb support. See Figure 9.

TROUBLE	POSSIBLE CAUSE	REMEDY
Crushing Contacts	Wire size not within specified tolerance.	Refer to Section 4 for specification.
	Insertor misalignment.	Refer to Paragraph 9.7.
	Combs misalignment.	Refer to Paragraph 9.4.
	Connector not properly seated on connector holder	Make sure connector is bottomed against stop and thumbscrew is tightened.
Cutting Improperly	Tool not properly cleaned.	Refer to Section 8.
	Insertor cutting edge damaged.	Replace insertors; refer to Paragraph 9.7.
	Tooling not properly adjusted.	Refer to Section 10.
Wires Not Held in Combs	Wire insulation diameter too small.	Refer to Sections 2 and 4 for wire and insulation sizes; refer to Section 12 for available small-wire separable comb.

Figure 10

4. Move insertor (handle) in and out of shear plate and, simultaneously, squeeze the backup plate until a slight, even drag is apparent—then hold the backup plate in position and tighten TOP and BOTTOM setscrews until slight outward pressure is detected. Release pressure on the backup plate and secure TOP and BOTTOM screws.

5. Again, check for slight drag on insertor. If drag is NOT even, alternately adjust both the TOP and BOTTOM screws, and setscrew, until proper adjustment is obtained.

6. Repeat this procedure for opposite side, if necessary.

7. Terminate several connectors and inspect the terminations.

11. TROUBLESHOOTING (Figure 10)

The tool is ready for use when each termination meets the requirements specified in Section 6, INSPECTION OF TERMINATIONS.

Use Figure 10 to assist in isolating troubles. The figure lists the troubles, the possible cause, and the remedy for correcting the situation.

12. CONVERTING TOOLS

MI-1 Tools may be converted to perform various functions by using the Conversion Kits listed in Figure 11. Note that this applies only to tools with separable combs made after January, 1981.

13. REVISION SUMMARY

Changes made per EC: 0990-0863-00

- Add tool 2-229378-5 to Figure 1, Section 2, Paragraph 5.1, Figure 8, and Figure 11.
- Changed tool repair address in Section 7.

TO \ TO CONVERT	STANDARD TOOL 229378-1	HALF-TAP TOOL 229378-3	MULTI-WIRE TOOL 2-229378-0	SHIELDED/IEEE TOOL 2-229378-3	GB STYLE TOOL 2-229378-5	LARGE-WIRE TOOL 231925-1
Standard Application		---	---	314112-1	229694-7 (2)	314111-1
Half-Tap Application	231290-1		231290-1	---	---	---
Multi-Wire Application	230596-1	---		---	---	230596-3
Shielded/IEEE Application	---	---	---		---	---
GB Style Tool	525129-1 (2)	---	---	---		---
Large-Wire Application	231928-1	---	231928-1	---	---	
Small Wire Combs●	231619-2	231619-2	231619-2	231619-2	---	---

● Insulation is less than 0.89 [.035] diameter.

Figure 11