

**PROPER USE GUIDELINES**

Cumulative Trauma Disorders can result from the prolonged use of manually powered hand tools. Hand tools are intended for occasional use and low volume applications. A wide selection of powered application equipment for extended-use, production operations may be available.

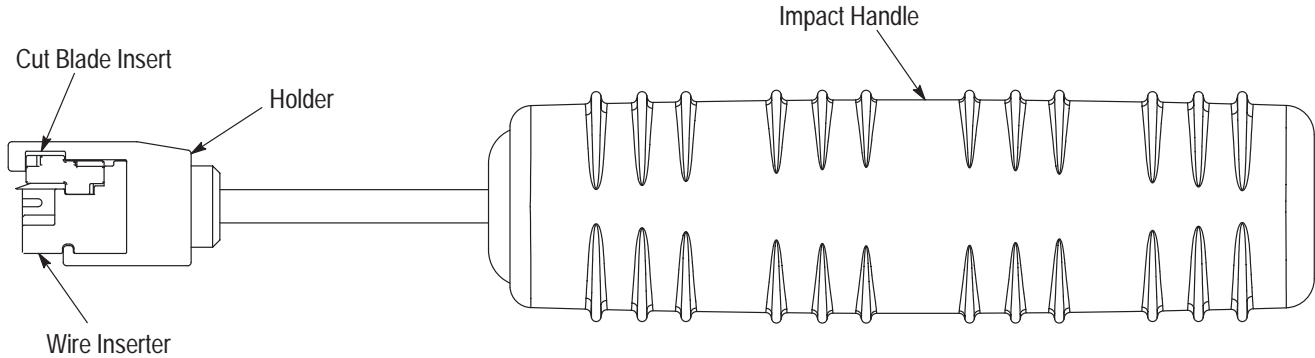

PRODUCT PART NUMBER	DESCRIPTION
1479245-1	CONNECTING BLOCK ASSEMBLY, 4 Pair
1479246-1	CONNECTING BLOCK ASSEMBLY, 5 Pair
1479247-1	WIRING BLOCK ASSEMBLY, 50 Pair with Mounting Legs
1479248-1	WIRING BLOCK ASSEMBLY, 100 Pair with Mounting Legs
1479249-1	WIRING BLOCK ASSEMBLY, 300 Pair with Mounting Legs
1479250-1	WIRING BLOCK ASSEMBLY, 50 Pair without Mounting Legs
1479251-1	WIRING BLOCK ASSEMBLY, 100 Pair without Mounting Legs
1479252-1	KIT, 50 Pair with Mounting Legs and 4 Pair Connecting Blocks
1479253-1	KIT, 50 Pair with Mounting Legs and 5 Pair Connecting Blocks
1479254-1	KIT, 100 Pair with Mounting Legs and 4 Pair Connecting Blocks
1479255-1	KIT, 100 Pair with Mounting Legs and 5 Pair Connecting Blocks
1479256-1	KIT, 300 Pair with Mounting Legs and 4 Pair Connecting Blocks
1479257-1	KIT, 300 Pair with Mounting Legs and 5 Pair Connecting Blocks
1479258-1	FRAME KIT, 300 Pair, with 4 Pair Connecting Blocks
1479259-1	FRAME KIT, 300 Pair, with 5 Pair Connecting Blocks
1479260-1	FRAME KIT, 900 Pair, with 4 Pair Connecting Blocks
1479261-1	FRAME KIT, 900 Pair, with 5 Pair Connecting Blocks
1479262-1	PANEL ASSEMBLY, Wiring Block, 100 Pair
1479263-1	PANEL ASSEMBLY, Wiring Block, 200 Pair
1479264-1	PANEL ASSEMBLY, Wiring Block, 400 Pair

Figure 1

**1. INTRODUCTION**

The 4-Pair Punch Down Tool 1725062-1 shown in Figure 1 is used to insert and trim wire with the 110Connect XC Category 6 connecting blocks, wiring

blocks, and kits listed in Figure 1. The tool is also used to install the connecting block to the index strip of the wiring block. For more information on the installation of connecting blocks and wiring blocks, refer to Instruction Sheet 408-8823.

**2. DESCRIPTION**

The 4-Pair Punch Down Tool is equipped with an impact mechanism to provide the force required to insert and trim 4 pairs of wire at once. The tool is also equipped with a reversible cut blade if the wires are not to be trimmed.

**DANGER** *The 4-Pair Punch Down Tool contains a sharp cutting blade. Improper use of tool may result in damage to the tool or bodily injury.*

**3. CONNECTING BLOCK INSTALLATION PROCEDURE**

Installation of the connecting block to the index strip may be made easier through the use of the 4-Pair Punch Down Tool. Refer to Figure 2.

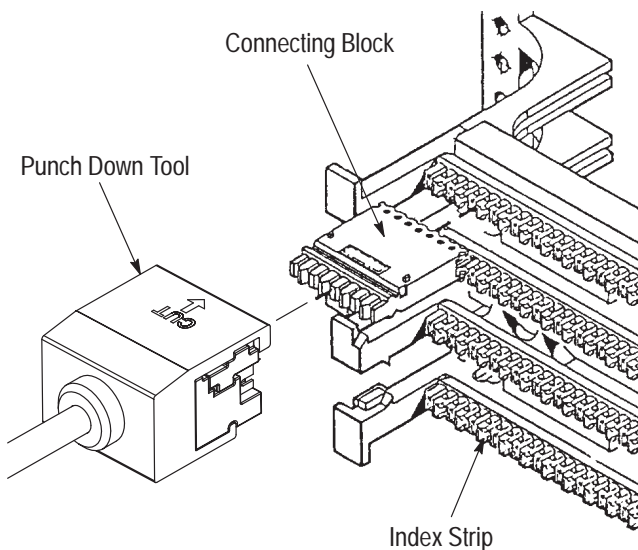

Figure 2

**4. INSERTING AND TRIMMING WIRE PROCEDURE**

1. Hand lace each wire into the appropriate slot on the connecting block or index strip.
2. Align the inserter blades on the tool with the wires.
3. Carefully slide the tool into place over the connecting block or index strip. Refer to Figure 2.

**CAUTION**

*Care should be taken to make sure the tool is located correctly to prevent damage to the connecting block or index strip. Damaged products should not be used.*

**NOTE**

*If cutting, be sure to verify the cut blade is in the proper position in the tool and is oriented correctly with the connecting block or index strip. An arrow similar to the one shown in Figure 3 indicates the cut blade location.*

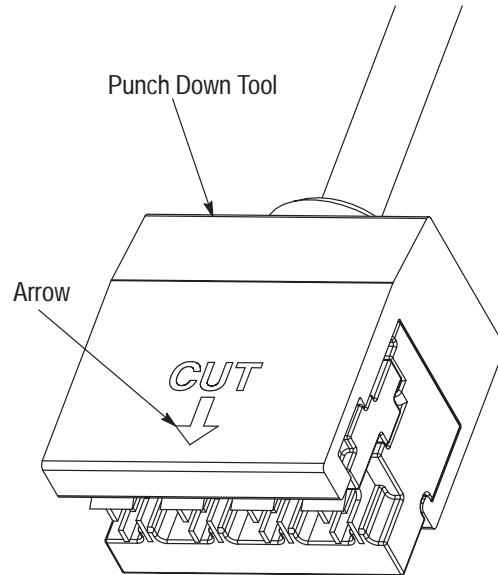

Figure 3

4. With the tool located properly, press down on the handle until the impact mechanism releases.

**NOTE**

*Multiple tries may be required if all wires were not trimmed at start of procedure.*

**5. SWITCHING CUT BLADE ORIENTATION**

1. To switch cut blade orientation, pull the head off the main handle body.
2. Slide the cut blade insert and the wire inserter out of the holder.
3. Flip the cut blade insert.
4. Slide the cut blade insert and wire inserter back into the holder.

**NOTE**

*Be sure to center the cut blade insert and wire inserter in the handle inserts.*

5. Re-install the handle.

**NOTE**

*If the cut blade insert and wire inserter are not properly centered, the handle can not be installed correctly. The handle prevents the inserts from coming out during normal operations.*

**6. REPLACEMENT/REPAIR**

If replacement parts are needed for the Punch Down Tool, refer to Figure 4 for specific replaceable components.

A complete inventory should be stocked and controlled to prevent lost time when replacement of parts is necessary. Order replacement parts through your Tyco Electronics Representative, or call 1-800-526-5142, or send a facsimile of your purchase order to 717-986-7605, or write to:

CUSTOMER SERVICE (038-035)  
TYCO ELECTRONICS CORPORATION  
PO BOX 3608  
HARRISBURG PA 17105-3608

For customer repair service, please contact an Tyco Electronics Representative at 1-800-526-5136.

**7. REVISION SUMMARY**

Initial release of document per: EC 0990-1033-03.

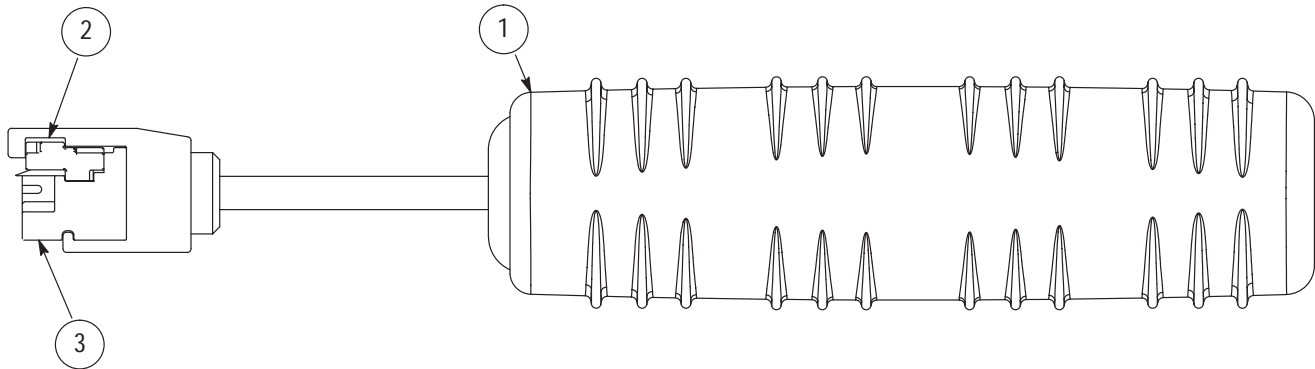

ITEM NUMBER	DESCRIPTION	PART NUMBER	QTY PER TOOL
1	Handle Assembly	1725067-1	1
2	Cut Blade Insert	1725064-1	1
3	Wire Inserter	1725063-1	1

Figure 4